



# Kuwait 4th Flow Measurement Technology Conference

3-5 December 2019  
Hilton Kuwait Resort



OFFICIAL SPONSOR



الراعي الرسمي



# JUSTIN HOLLINGSWORTH

Innovation Engineering Manager



**EMERSON**<sup>TM</sup>

# Beam Pump Wellhead Trial

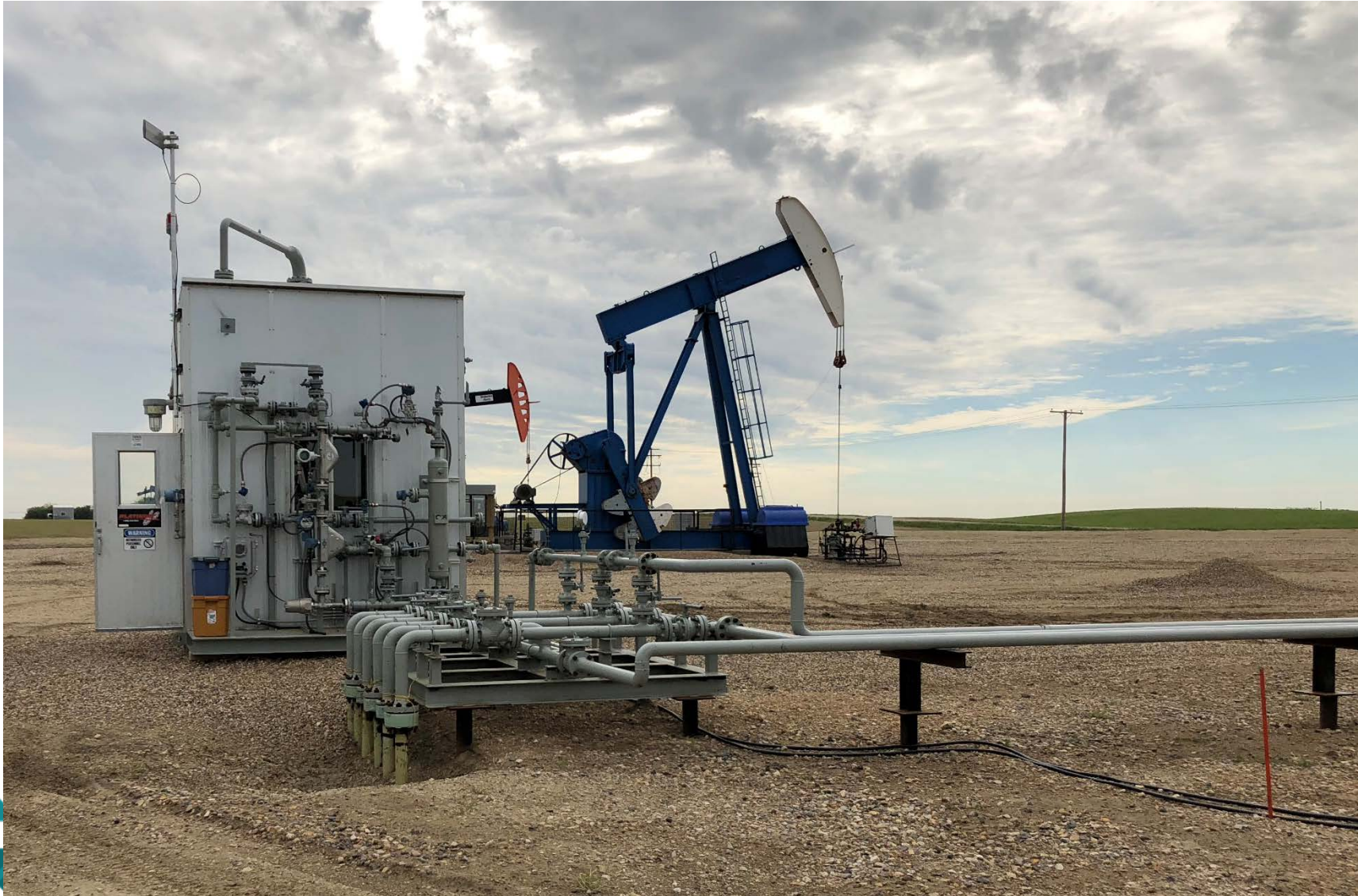

## Test phases

Mobile test skids with coriolis meters from 4 manufacturers, moved every 4-6 weeks within the Bakken

**Built-in separator for real-time reference.**

12 pilot meters were then permanently installed, using group separator as reference system over the course of 1 year.

# Wellhead Measurement Package



## 3 Phase Wellhead Metering Package

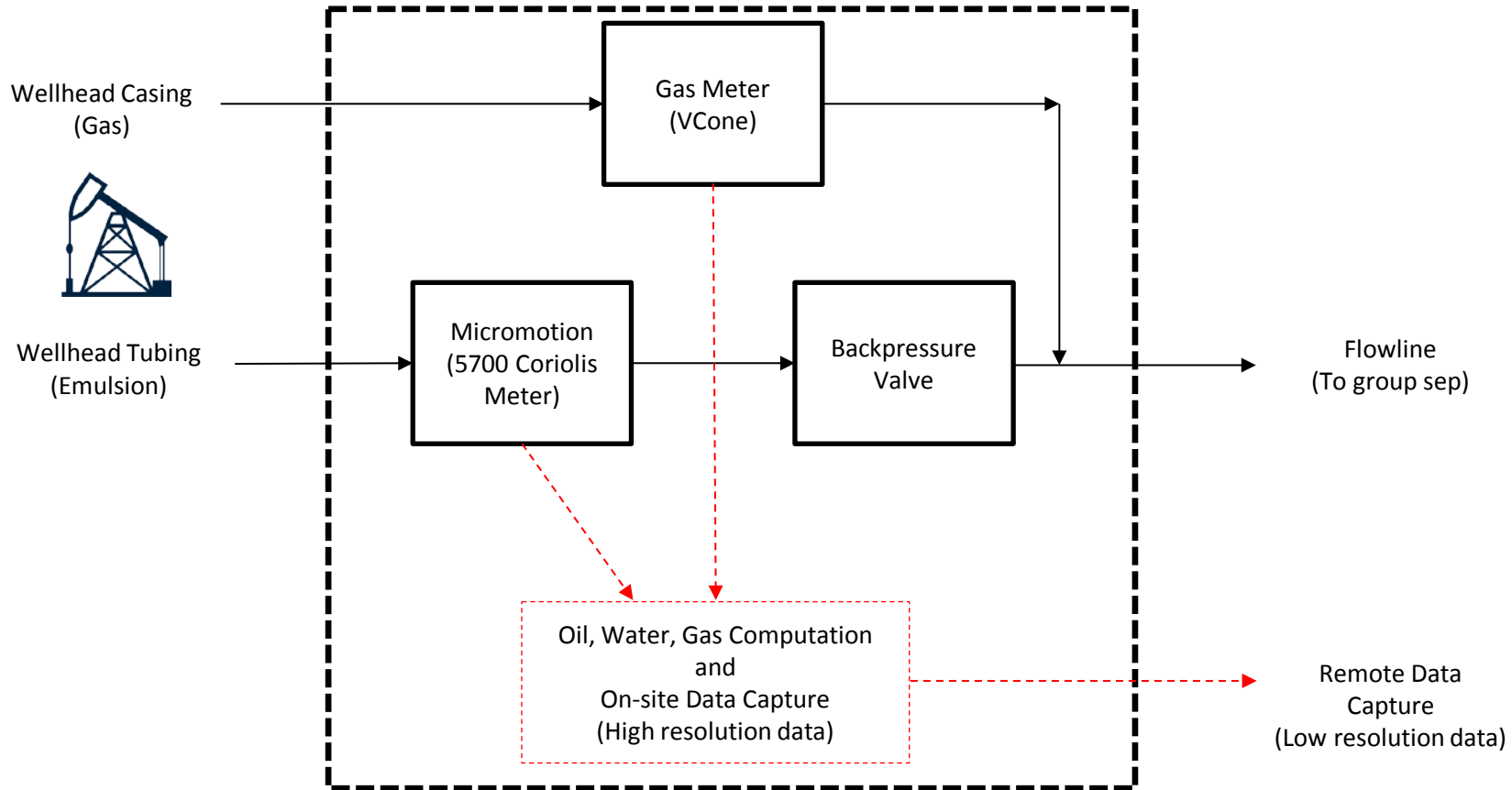

# Satellite Trial – Proration Pilot

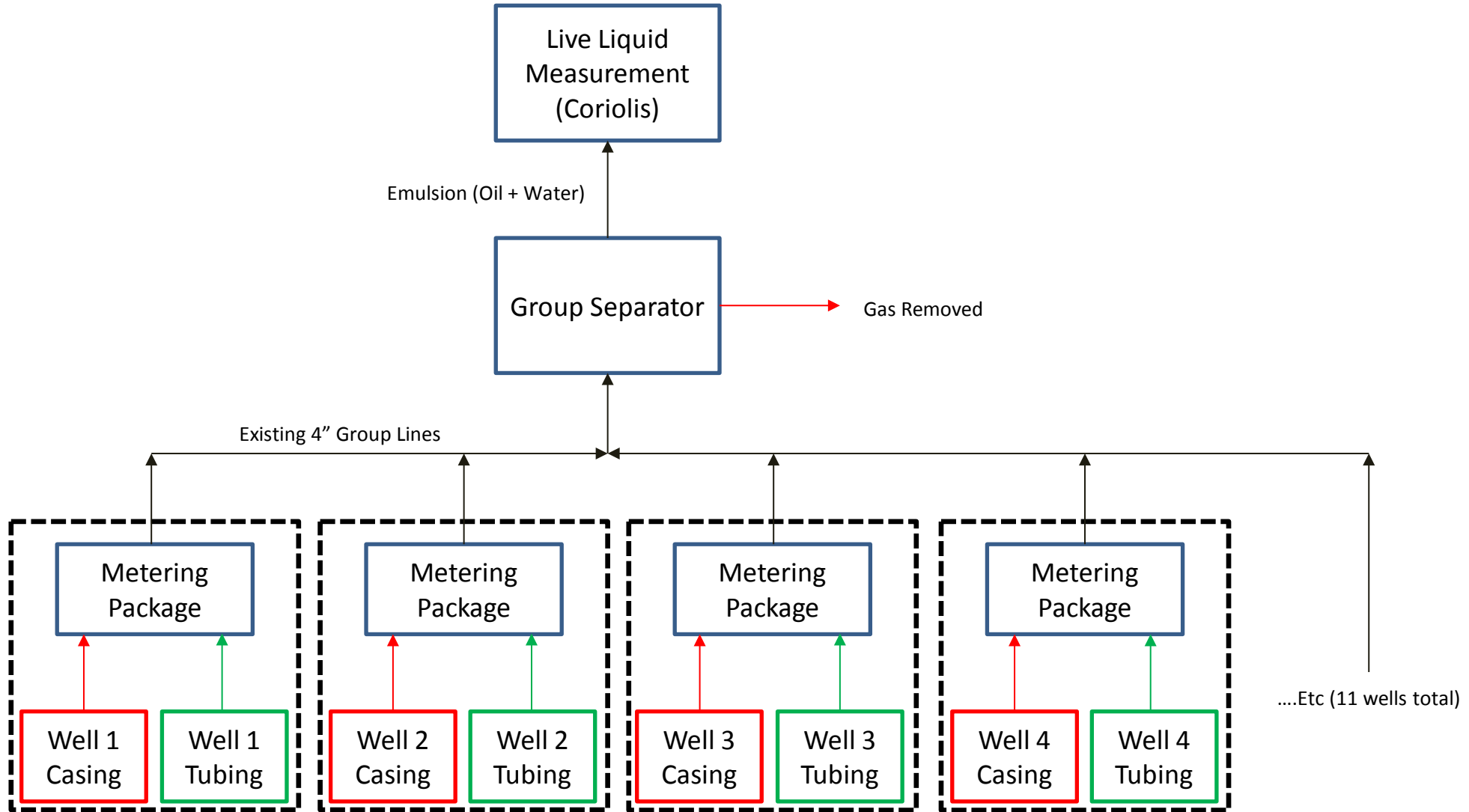

# Challenges for Producers

- Getting timely insight into operational issues
  - Reducing operational reaction time
  - Reducing down time
  - Real time production monitoring of liquids and gas
- Monitoring EOR activities
  - Continuous, simultaneous monitoring of all production wells in communication with injection wells
  - Immediate detection of water breakthrough

# Challenges for Measurement

- Transient or pulsating flow
  - Flow will sometimes be in reverse
- Multiphase: Oil, Water and Gas
- Need to measure oil independently of water
  - When gas is in the process, density measurement alone can't solve

$$watercut = \frac{\rho_{liquid} - \rho_{oil}}{\rho_{water} - \rho_{oil}}$$



# Coriolis Drive and Pickoff Coils Keep the Sensor Tubes Vibrating



Process fluid enters the sensor and flow is split with half the flow through each tube. The sensor flow tubes are vibrated in opposition to each other by energizing a drive coil. Tubes are oscillated at their natural frequency.

Magnet and coil assemblies, called pick-offs, are mounted to the flow tubes. As each coil moves through the uniform magnetic field of the adjacent magnet it creates a voltage in the form of a sine wave.

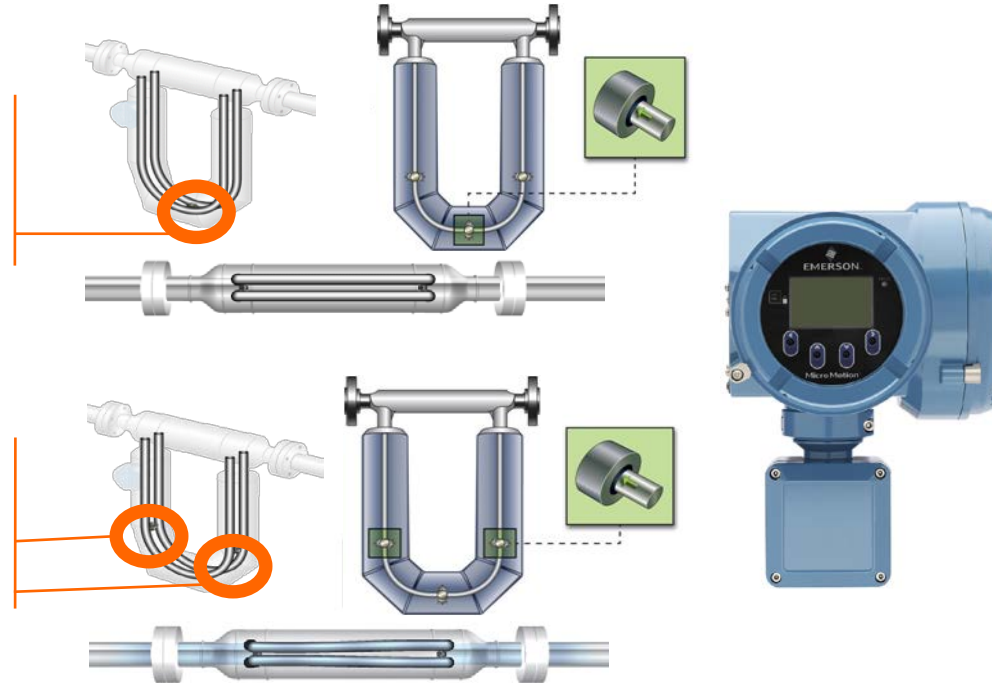

## Calculated Outputs:

- Actual Volume @ Line
- Volume @ STD
- Watercut
- Net Oil / Water
- Gas Void Fraction (GVF)
- Liquid rate for wet gas
- Shrinkage corrections
- Well test automation for up to 48 wells
- Solids Concentration
- Full Diagnostics Suite

# Why Coriolis for 2-Phase or Multiphase?

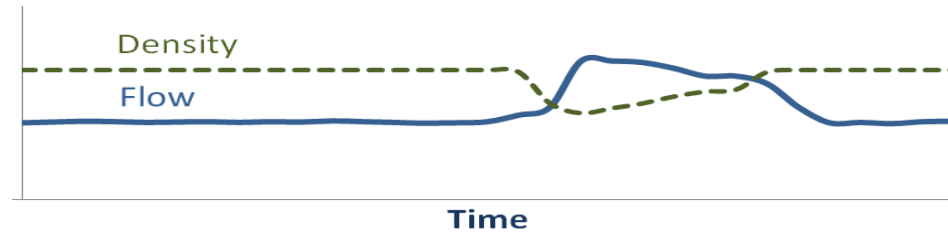

## Coriolis provides unprecedented insight

- Access to **mass** and **density** enables insight on remediated liquid flow
- Ability to positively **identify two phases** with drive gain

## Other single phase technologies

- Single variable with no insight
- Higher maintenance



# Drive Gain is a Sensitive Indicator of Single-Phase vs Multiphase Conditions

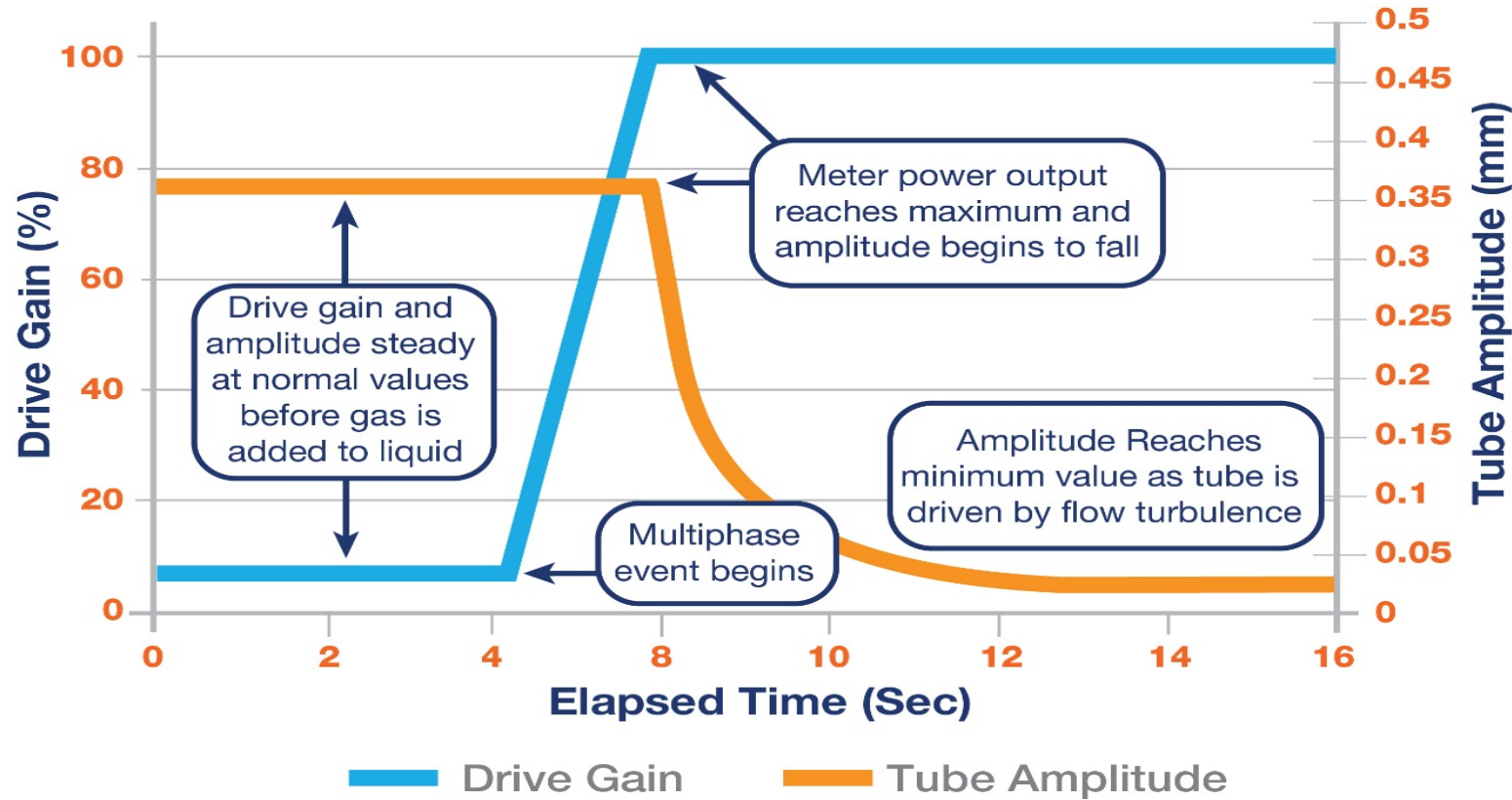

# Multi-Variable Outputs and Drive Gain Give Insight to Phase Conditions



Independent measurement  
of **mass** and **density** yield  
insight into multi-fluid and  
multi-phase events

Drive gain indicates  
presence of **multiple phases**

Can detect  
Liquid composition changes  
Gas in liquid  
Mist in gas

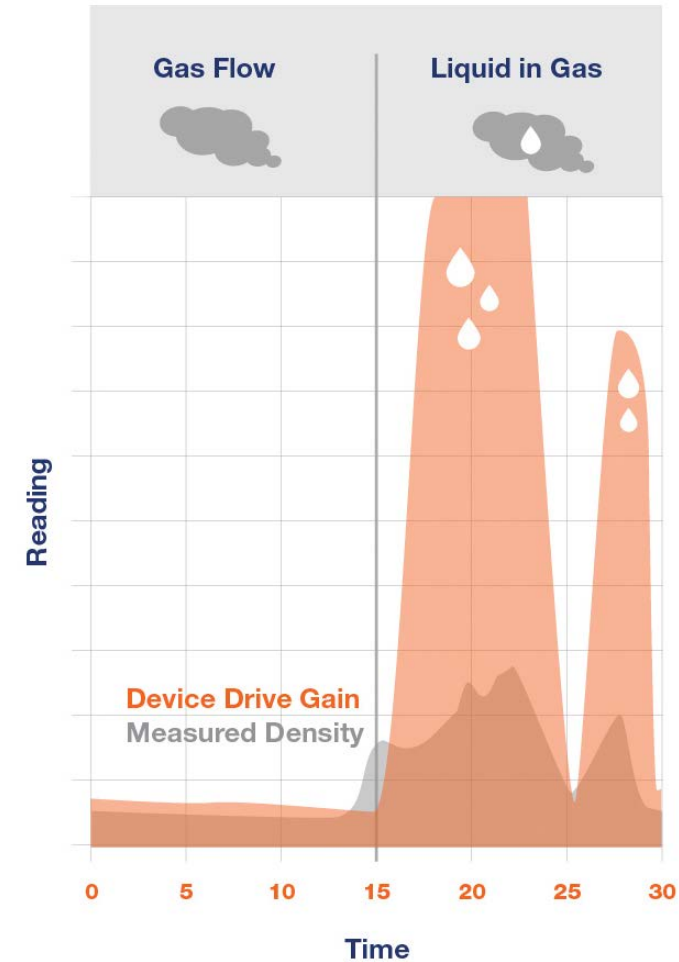

# Flow Regimes in the Real World

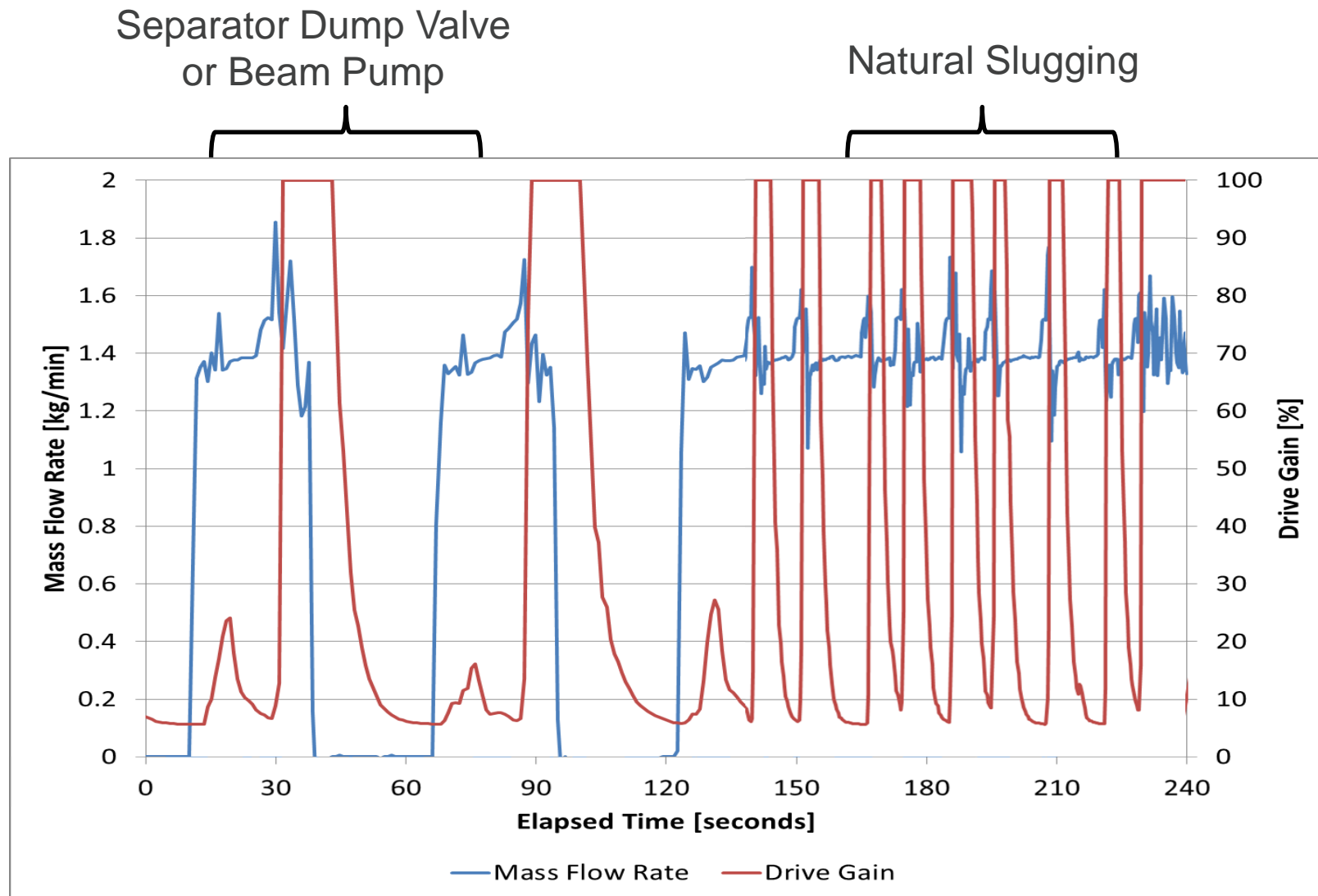

# Traditionally Single Phase Measurement Technology in Multiphase Processes

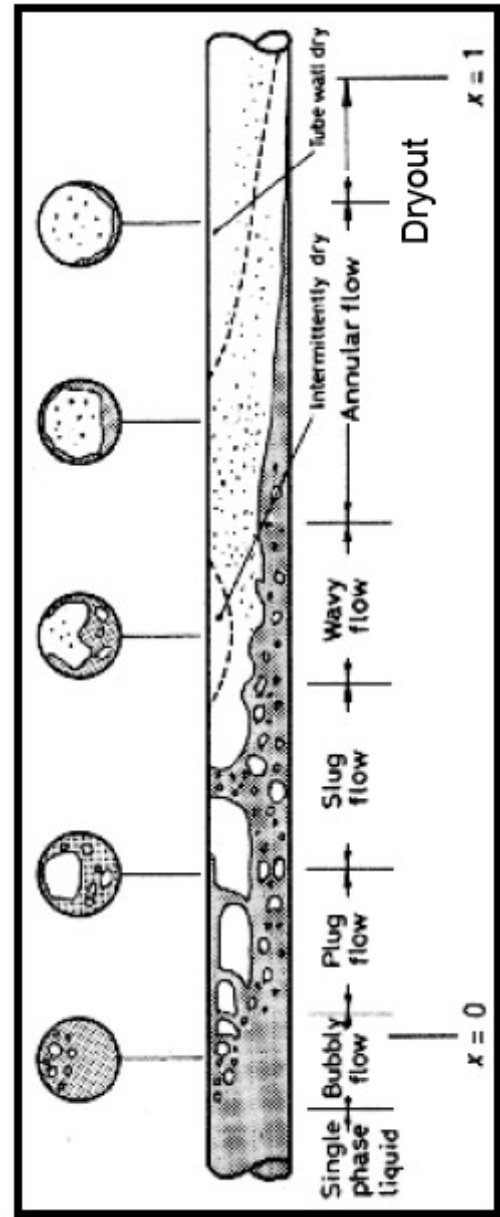
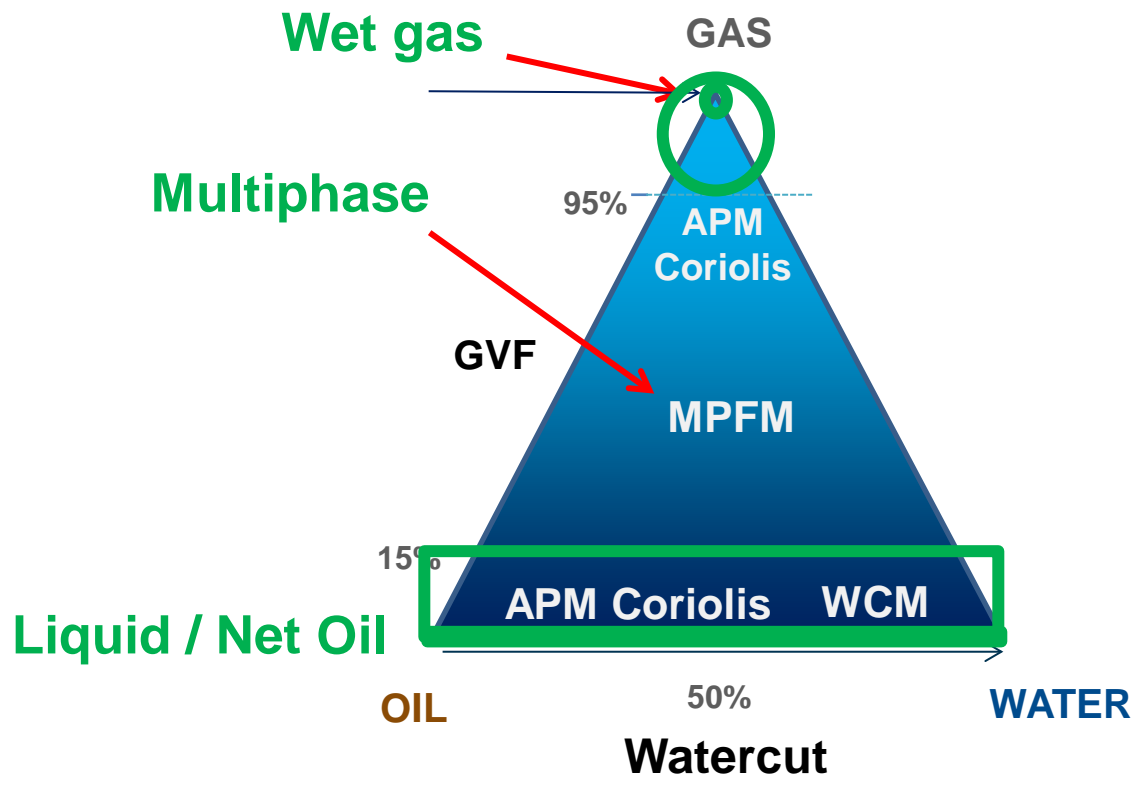

# Coriolis with Advanced Phase Measurement versus Other Multiphase Technologies

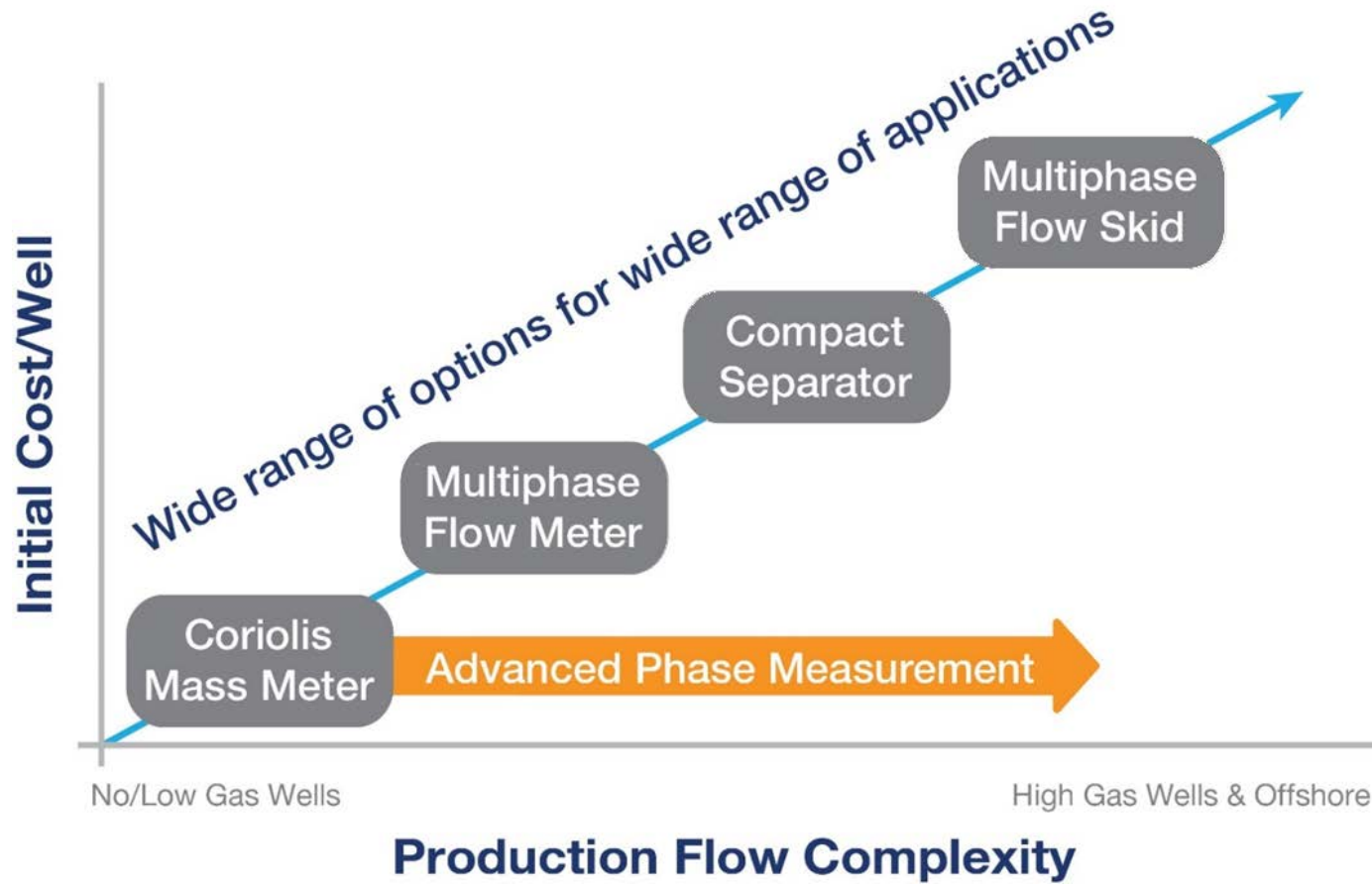



# Trial Results

- Wellhead skid vs. satellite total fluids within +/-1%, ~3% net oil
- Immediate water breakthrough detection
- Real-time proration confidence
- Seasonal variation in gas at meter
  - More gas in cold weather, higher viscosity
  - Keeping well pumped off improves separation in well
    - Gas stays in the casing and liquid in the tubing



# Learnings & Benefits

- Sensor design and modern electronics are critical, in addition to algorithms to improve performance.
- Sizing and installation best practices are more critical in two-phase or multiphase applications.
- Use all the data that coriolis meters have to offer
  - Collect process variables and diagnostics for more insights
- Coriolis meters on the reference system help validate measurements after test separator.

# Learnings & Benefits

- Experiments with injection changes show immediate effects
  - Would be missed with bi-weekly well testing
- See effects of test separators on production
  - 20psi increase on tubing from test separators reduced production, recovered after a day. Separator testing not representative of normal, off-test production
- Captured downtime immediately, rather than at next test
  - Reduced reaction time to downtime

# Summary



- **Sensor** and **remediation** algorithm design are critical
  - Use low frequency, “U” shaped meters and proven algorithms on modern electronics.
- Errors due to multiphase conditions **need to be remediated** for **flow** and **density** measurement for accurate oil/total volumes
- Continuous measurement with **coriolis meters** at the wellhead is possible and has **significant benefits**
- Results verified in **field trials** and **independent lab test**



**THANK YOU**

